

# CAPTAIN

**LOADER – SELF LEVELLING** WITH STANDARD BUCKET (1.25m / 4 feet)

(1.5m / 5 feet Bucket Option Also Available)

**Innovation**  
**Shock Absorber**



## FEATURES

**CAPTAIN LOADER** specifically designed to maximize the performance of the front loader and tractor. They offer a high lifting capacity, perfect for landscaping or light utility work. The Captain Loader operates with single joystick control and has quick & easy attachment and detachment of bucket.



EURO Type Quick Hitch with Lever



3rd Function Valve



Flow Control Valve on DCV to Control Dropping Rate of Loader Boom



Single Joystick with Positive Locking System (Comfortable Positioning for Operation)



Unique Additional Rectangular Support Crossbars all Across the Loader

www.captainagri.com

## Loader Model L2-5ME

Suitable for Model 263/283/303 MST



**CAPTAIN**  
AGRI MACHINERY

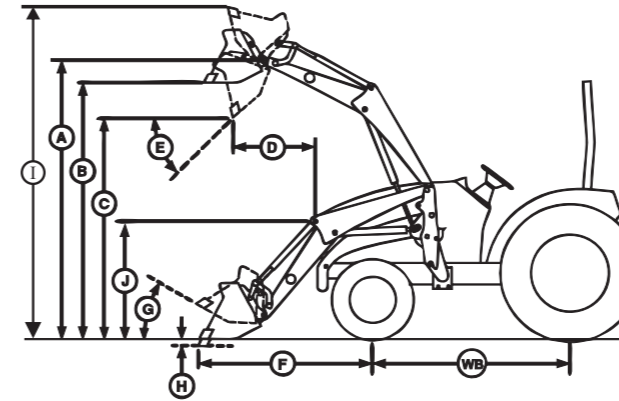

**500 KG**  
**Lift Capacity**

**MECHANICALLY**  
**SELF LEVELLING**

No.	Specification# (Standard Bucket)	
A	Pivot Pin height at maximum, Inch (mm)	93 (2375)
B	Height bucket parallel to ground at maximum, Inch (mm)	83 (2108)
C	Bucket fully tilted bottom height, Inch (mm)	69 (1742)
D	Bucket reach when fully dumped, Inch (mm)	Bonnet - 12 (311) & Hook - 9 (224)
E	Bucket tilt (dump) angle	54°
F	Bucket forward position from front wheel center, Inch (mm)	60 (1534)
G	Bucket roll back angle at ground level	42°
H	Bucket (parallel) height below ground level (digging depth), Inch (mm)	3 (77)
I	Bucket fully tilted top height, Inch (mm)	104 (2651)
J	Loader frame front top to ground level, Inch (mm)	40 (1027)
WB	Wheel base, Inch (mm)	59 (1490)
	Grill guard (bumper - front hood/bonnet)	Standard
	Bucket width, Inch (mm)	49 (1250)
	Lift capacity (at pivot pin, max. height), lbs(kgs.)*	1102 (500)
	Loader weight without attachment, lbs(kgs.)	639 (290)
	Standard bucket weight, lbs(kgs.)	115 (52)

\*+/- 5% tolerance variations

\*Safe working load 400kg with 300kg counter weight.

Note : Products undergo continuous upgradations. Hence, above mentioned specifications are subject to change without prior notice.

Dimensions are with Agriculture Tyre (F 180/85D12 and R 8.30 x 20).

Counter weight box is optional but recommended for safety & better performance.

## Also Available Different Types of Attachments



Grapple Fork Bucket

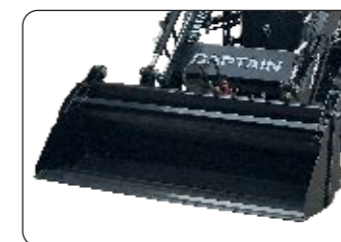

4 in 1 Bucket



Pallet Fork

## CAPTAIN AGRI MACHINERY EXIM LLP

Veraval (Shapar), District : Rajkot (Gujarat) INDIA. Pincode - 360024.

Ph./Landline : + 91 281 299 4386, Mo : +91 99250 40445.

Email : exports@captaintractors.com

Dealer Imprint Area

www.captainagri.com